

# United States Fire Administration



Technical Report Series

---

## Aerial Ladder Collapse Incidents



Federal Emergency Management Agency

---



United States Fire Administration

This document was scanned from hard copy to portable document format (PDF) and edited to 99.5% accuracy. Some formatting errors not detected during the optical character recognition process may appear.

# **Aerial Ladder Collapse Incidents (April 1996)**

**Investigated by: J. Gordon Routley  
Reade Bush**

**This is Report 081 of the Major Fires Investigation Project conducted by Varley-Campbell and Associates, Inc./TriData Corporation under contract EMW-94-C-4423 to the United States Fire Administration, Federal Emergency Management Agency.**



**Federal Emergency Management Agency**

---



**United States Fire Administration**

## **Aerial Ladder Collapse Incidents**

**Investigated by:**            **J. Gordon Routley**  
   **Reade Bush**

**Local Contacts:**            Commissioner Howard Safir  
   Battalion Chief Tom Haring  
   FDNY  
   250 Livingston Street  
   Brooklyn, NY 11201  
   (718) 722-3404

   Chief Randy Justus  
   Mundelein Fire Department  
   169 North Seymour Avenue  
   Mundelein, IL 60060  
   (708) 949-3260

   Commissioner Neil Curry  
   Deputy Commissioner Chris Kiernan  
   Yonkers Fire Department  
   Yonkers, NY 10701  
   (914) 377-7500

   Asst. Chief Nick Dvorscak  
   East Chicago Fire Department  
   3901 Indianapolis Boulevard  
   East Chicago, IN 46312  
   (219) 391-8472

   Chief Benjamin F. Brenner  
   Admin. Deputy Chief John Bereheiko  
   Atlantic City Fire Department  
   States and Pacific Avenues  
   Atlantic City, NJ 08401  
   (609) 347-5590

### **INTRODUCTION**

   This report addresses five separate incidents in which fire department aerial ladders collapsed. The most serious of these incidents occurred in New York City, where one man died and his wife, two young

children and two firefighters were injured when an aerial ladder collapsed during a rescue attempt. Two of the other incidents also resulted in serious injuries to firefighters.

Each of these incidents involved the collapse of an aerial ladder due to structural failure. Four of the five ladders were being used in situations at fires that involved extending the ladder at a low angle of elevation. The fifth incident occurred during a high angle rescue training session where the ladder was being used to support rappelling personnel. Several similar incidents have occurred in recent years, including a number that resulted in deaths or serious injuries.

These incidents indicate a significant potential problem with existing aerial ladders that were not designed to provide the structural capabilities of ladders that are currently in production. Hundreds of similar aerial ladders are currently in service in United States fire departments. This emphasizes the need for aerial ladder operators to be properly trained and thoroughly familiar with the capabilities and limitations of their particular units, so that they will be able to recognize situations that are beyond the safe operating limits of their equipment.

Training materials and operating manuals are very important sources of information and should always be available to the operator of an aerial device. Many aerial ladder operators do not have access to the manuals and other technical information that were provided (or should have been provided) when the units were delivered. In some cases the information that was provided may be inadequate or difficult to interpret and additional research may be needed to determine the operating limits of an aerial device.

It is also very important to regularly have aerial devices tested and certified, to ensure that they are in proper operating condition and do not have any hidden damage or defects.

## SUMMARY OF KEY ISSUES

Issues	Comments
Operator Training	All operators must be adequately trained before being authorized to operate aerial equipment. The training must provide a thorough understanding of the specific operating limits of the particular aerial device and recognition of unsafe operating conditions. The training should also provide sufficient practice in operating the aerial device to ensure that the operator can safely perform all required tasks.
Operating Manuals	The manuals that are delivered with each vehicle should be the primary source of technical information to determine a ladder's capabilities and operating limitations. The manuals should always be available to the operators.
Design Criteria	The design criteria in NFPA 1904 for aerial ladders and other aerial devices were upgraded in 1991. Ladders built to earlier standards may have much more limited operational capabilities, particularly when extended at low angles.
Load Limits	The allowable live load on a ladder decreases rapidly at low angles and greater horizontal extension. Many of the "old design" aerial ladders can be placed in configurations where the ladder was not designed to support any live load. It may be necessary to obtain additional information from the manufacturer to determine the operating limits and test loads.
Inspection and Testing	All aerial ladders should be regularly inspected and tested to ensure that they are safe and in proper condition for continued operation.

Failure Analysis	When aerial ladders fail, it is important to gather information about the operating conditions and to obtain a professional engineering assessment of the cause.
Warning Devices	Some new aerial ladder designs have the capability to warn the operator if they are overloaded or placed in an unsafe configuration.

### **OLD DESIGN VERSUS NEW DESIGN LADDERS**

All of the aerial ladders involved in the incidents described in this report were “old design” ladders. This refers to ladders that were not designed to meet the load capacities that are specified in the 1991 edition of NFPA 1904, *Standard for Aerial Ladder and Elevating Platform Fire Apparatus*. Earlier editions of the NFPA standard for aerial ladders did not specify any minimum load requirements and many aerial ladders were not designed to support any load when extended at low elevation angles.

The 1991 edition of the NFPA standard requires an aerial ladder to be capable of operating in any position that the ladder will reach, while supporting a minimum tip load of 250 lbs. The 250 lb. load represents the weight of one firefighter and aerial ladders can be rated by the manufacturer to support greater loads in increments of 250 lbs. The design criteria also require a minimum 2:1 safety factor for the strength of any structural component and a 1.5:1 safety factor for stability of the vehicle.

The design of aerial ladders did not change abruptly in 1991. Ladders that meet or exceed the current standard became available several years before the minimum tip load requirement was adopted, and many ladders that were built prior to 1991 meet or exceed the current requirements. The new standard caused manufacturers to end production of the older design ladders and all of the aerial ladder manufacturers in the United States now use the current NFPA standard as a minimum requirement.

Some of the ladders that were still in production when the standard changed had evolved from basic designs that originated prior to 1940. There are hundreds of these aerial ladders still in service that were constructed by several different manufacturers. These older designs have

proven over more than five decades to be very reliable when used at relatively steep angles of elevation; however, they were not designed to be extended and operated at low elevation angles. The older ladders are also very limited in their ability to resist lateral forces.

The trade-off for the extra strength in the newer ladders is additional weight and bulk, which requires a higher horsepower engine to drive the vehicle and operate the ladder, and a larger capacity hydraulic system. The increase in size and weight of the vehicle and the addition of a third axle to carry the load tends to make the newer units more difficult to maneuver and position. The increase in size and weight for 100 foot ladders with a rated capacity of 250 lbs. is relatively modest; however ladders with 500 lb. and higher capacities are significantly larger and heavier than the older units.

The following incident report provides detailed information on one aerial ladder that collapsed in New York City. Brief reports are provided on four additional cases, all of which have several similarities and provide additional emphasis on the problem.

## **NEW YORK CITY INCIDENT**

A 100 foot aerial ladder collapsed as firefighters were attempting to rescue a family from their sixth floor apartment in the Williamsburg section of Brooklyn, early on a Sunday afternoon, November 20, 1994. Smoke and flames were issuing from a fifth floor apartment on the front side of the six story building when the first alarm companies arrived. Smoke and heat conditions were building-up rapidly on the sixth floor, trapping the family of two adults and two children in their apartment.

The first arriving ladder company, Ladder 104, stopped in front of the building and raised their aerial ladder to the fifth floor, adjacent to the fire apartment (see Figure 1). In this situation the second due ladder company, Ladder 108, is expected to provide a ladder to the roof. Because Ladder 104 is a tractor trailer apparatus and several other vehicles were parked on the street in front of the fire building, Ladder 108 had limited access to position their apparatus within reach of the building.

Ladder 108 stopped at the intersection so that the officer could evaluate the situation. The street changes direction between the intersection and the fire building, resulting in a wide triangular-shaped



Figure 1. Apparatus Positions at New York City Ladder Collapse

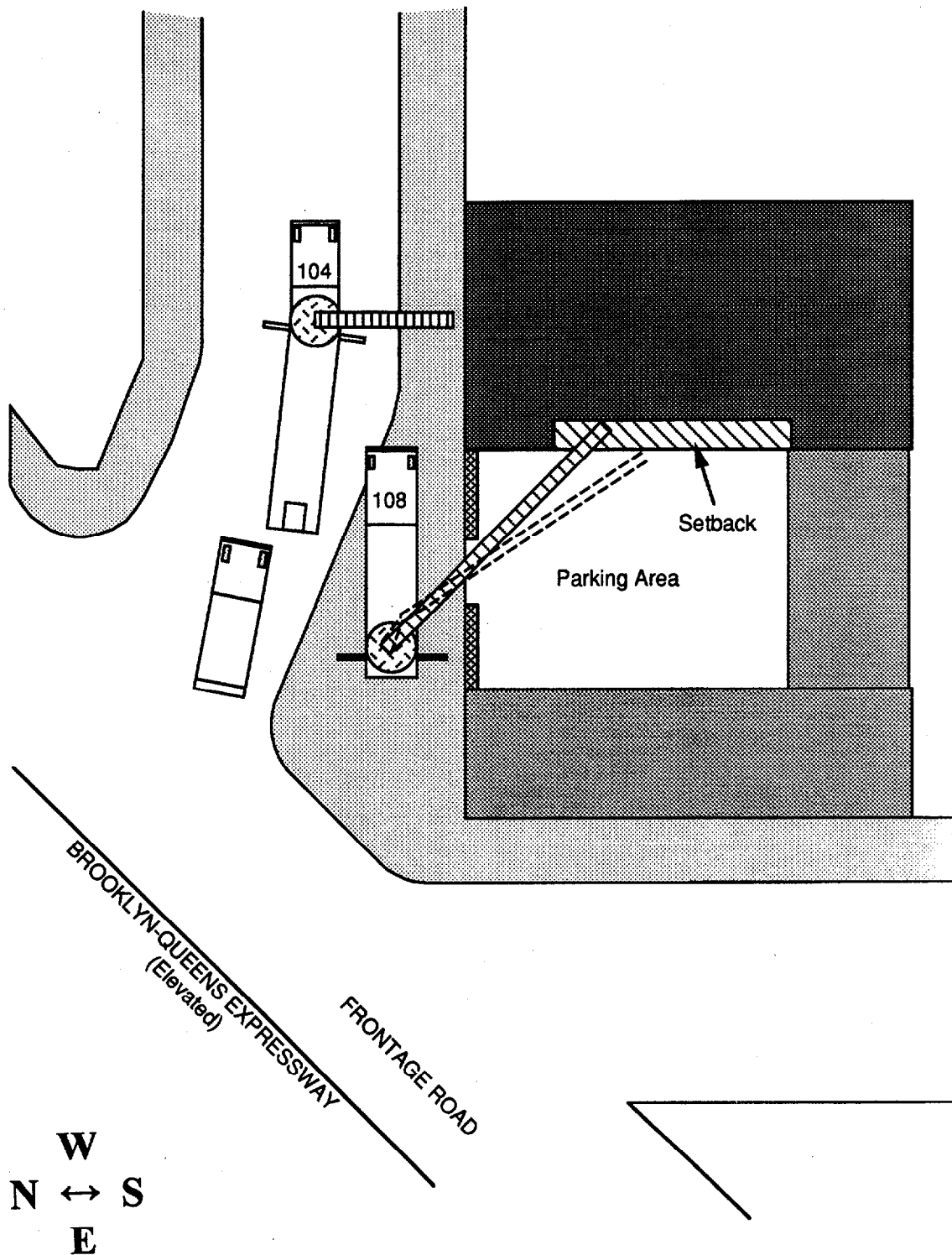

sidewalk area. Ladder 108 was positioned on this sidewalk area to obtain the best position to ladder the roof for vertical ventilation. After positioning the truck, the chauffeur went to the rear and began to lower the outriggers for ladder operations.

A firefighter, who was assigned to perform outside ventilation, dismounted from the right side of the vehicle and almost immediately heard someone calling for help. He spotted the father leaning out through a sixth floor window at the side of the building. There was smoke coming from the window and from adjacent windows on the fifth and sixth floors, indicating that the man was in imminent danger. He appeared to be in great distress and in need of immediate rescue.

The window is on the side of the building, approximately 30 feet back from the sidewalk, overlooking a fenced-in parking area (see Figure 2). When the building was originally constructed this window would have opened into a lightwell between two similar buildings; however, the adjacent building has been demolished, leaving the window exposed. The area directly below the window is a fenced-in setback.

The firefighter advised the chauffeur of the rescue situation; however, the chauffeur did not actually see the man until he reached the operating pedestal. At that point he recognized that the window was beyond the recommended reach of the aerial ladder, but within its physical reach capabilities. The window could not be reached with any of the portable ground ladders that are carried on the apparatus.

Repositioning the truck to reduce the horizontal reach would have taken several minutes. The chauffeur would have had to raise and retract the outriggers, back out into the intersection, turn around in the street, then maneuver the truck backward between parked vehicles, around the other fire apparatus and through the narrow opening into the parking lot below the window.

It appeared that time was critical due to the man's excited condition, and the chauffeur believed that it would be feasible to rescue the man with the tip of the ladder supported by the building. After quickly considering the alternatives, the chauffeur decided to attempt the rescue. He was able to position the ladder with the tip of the left beam resting on the sill of the window where the man was located.

## Figure 2. Sequence of Events at New York City Ladder Collapse

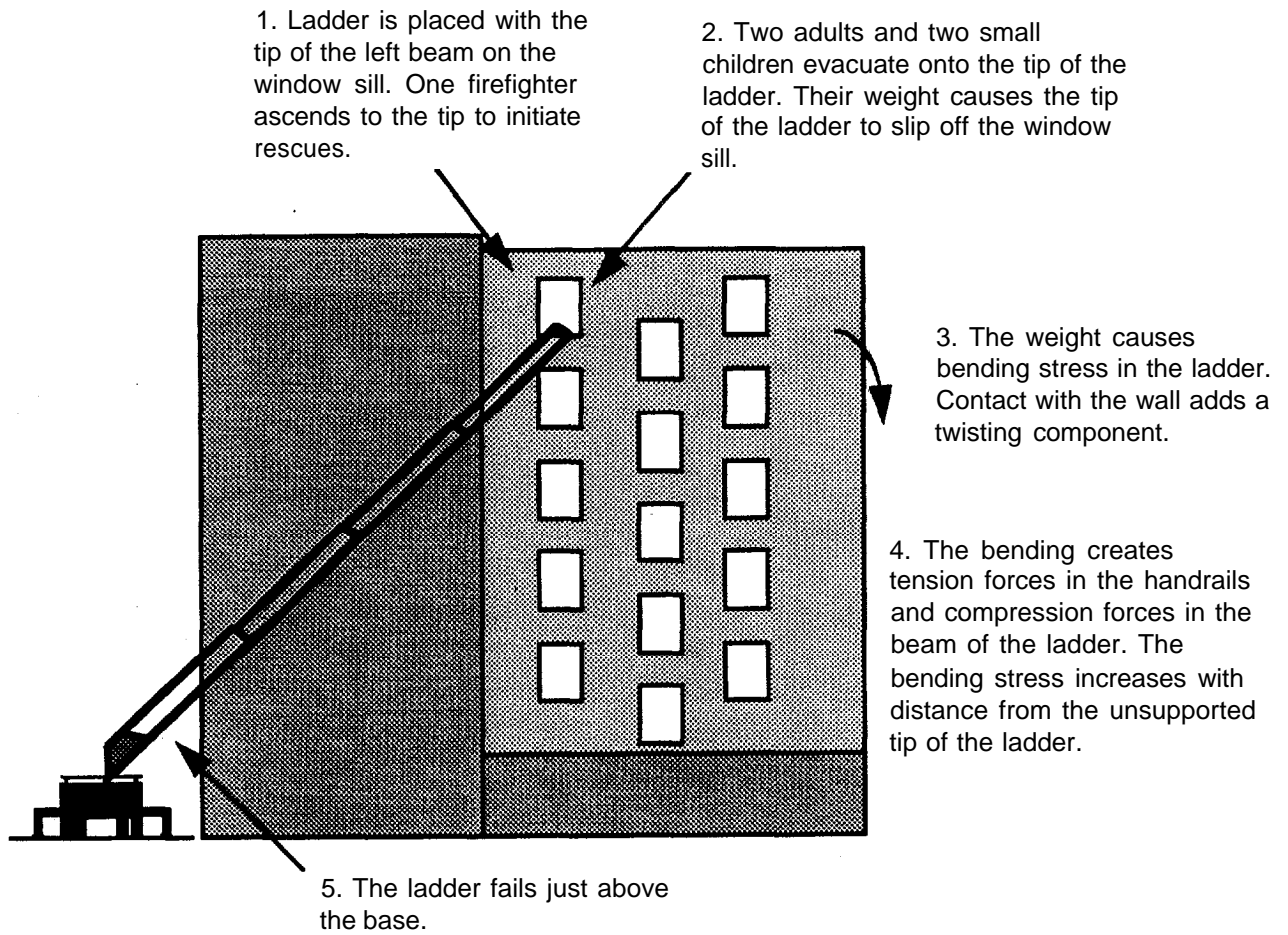



Courtesy FDNY

In a recreation of the FDNY Ladder 104 collapse scene, Ladder 112 is positioned with its ladder extended to the window where the occupants were trapped. The ladder is extended 91 feet at a 31 degree elevation angle.



Courtesy FDNY

Prior to the collapse, the tip of the left rail rested on the window sill. The weight of the occupants caused a twisting force to the unsupported right side.



Courtesy FDNY

The twisting failure occurred in the lower right bed section, collapsing the ladder to the right side.



Courtesy FDNY

The primary failure in the bed section caused secondary failures in the fly sections.

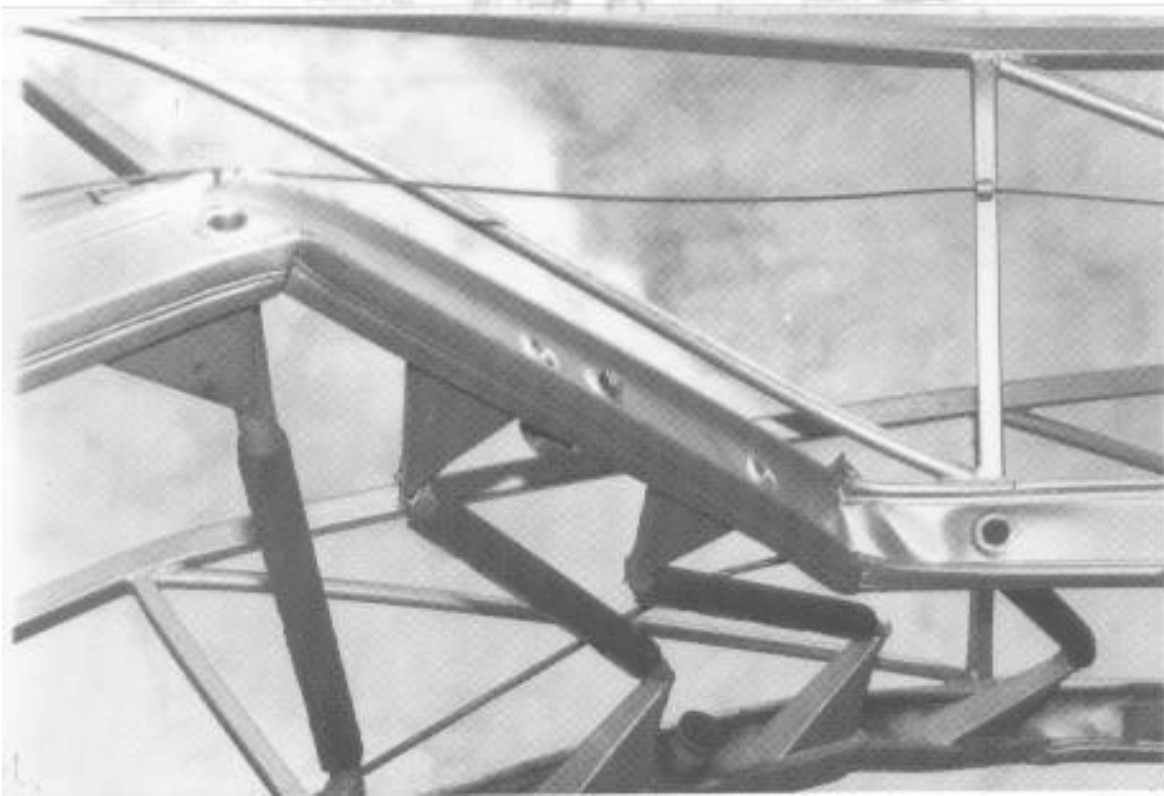

Courtesy FDNY

This close-up view shows the damage sustained by beams and rungs in the area of the primary failure.

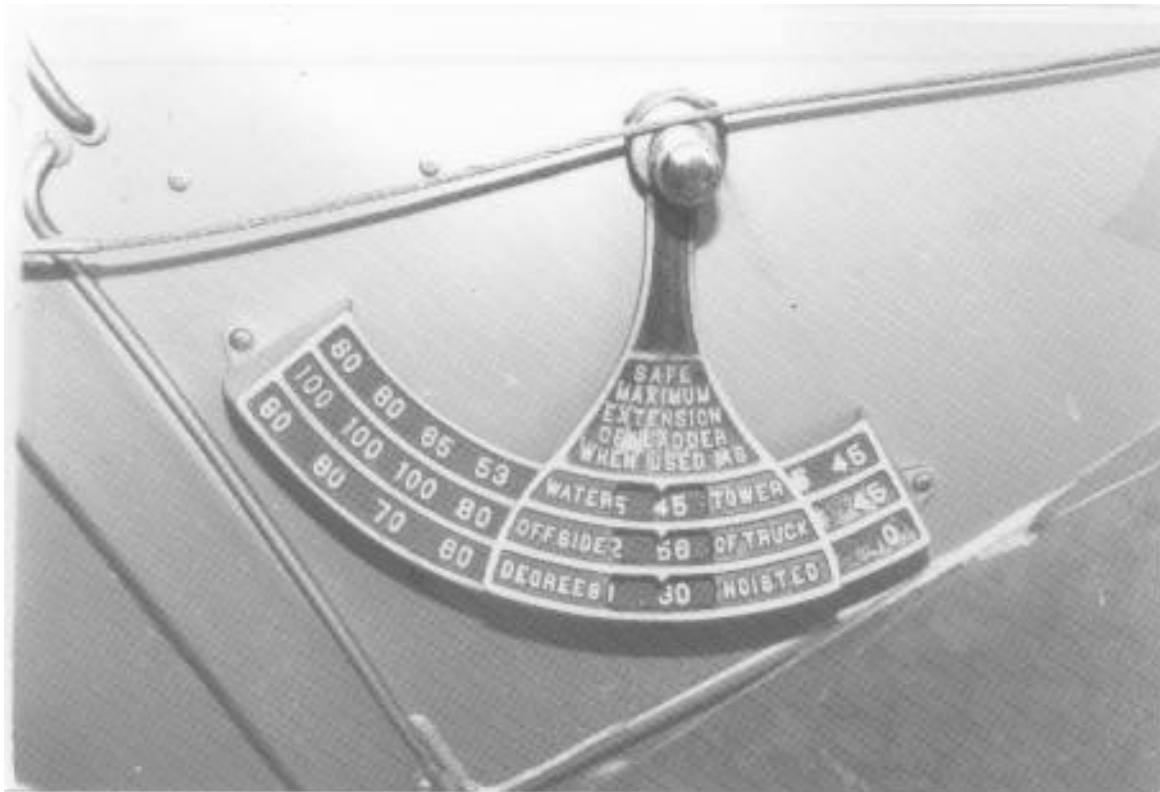

Courtesy FDNY

The inclinometer shows that the maximum safe distance of extension for the 31 degree angle is approximately 56 feet.

The firefighter quickly climbed up the ladder to assist the man, who would have to squeeze through a narrow window opening to reach the ladder. As he reached the window, however, the man reached out and handed a young child to the firefighter. An instant later a second child was handed out to the firefighter, then the mother began to climb out through the window opening. The firefighter tried to tell her to wait, but he was unable to communicate with any of the family members who did not speak English.

The firefighter tried to descend with the two children as the chauffeur started up the ladder to assist him. He was only able to descend two rungs before the mother reached the ladder. She took hold of the outboard side rail and leaned away from the building, which caused the tip of the ladder to slip off the stone sill. As soon as it slipped off the sill the tip dropped and scraped against the brick below the window.

Recognizing that the ladder was now unstable, the chauffeur shouted to the firefighter to come down as quickly as possible and turned back to descend himself. Before the firefighter could move, however, the father came through the window opening and dropped two to three feet onto the tip of the ladder. As his weight hit the tip, the ladder began to collapse, dropping quickly to the ground.

The 37 year old father died instantly when he hit the ground after falling approximately 50 feet. The firefighter held on to the two children, aged four and six, and rode the ladder down to the ground. The 31 year old mother also held onto the collapsing ladder. All four were treated for serious injuries, including multiple fractures, and were hospitalized in serious, but stable condition. The chauffeur, who was close to the base of the ladder, was thrown to the ground and received less serious injuries.

A second alarm was transmitted as many of the firefighters on the scene went to the assistance of the injured civilians and firefighters. The fire was confined to one apartment and controlled with no additional injuries.

The entire sequence of events, from the arrival of Ladder 108 at the incident scene until the first radio report of seriously injured personnel, took less than 120 seconds.

### Time Sequence - Brooklyn Box 224 11-20-94

- 1302 Telephone alarm for 252 S. 4th Street, reported fire on the 4th floor.  
Dispatched: E221 E216 L104 L108 BN35 E229
- 1303 Additional Dispatch: RS2, SQ1
- 1304 Additional reports indicate working fire on 4th or 5th floor of a six-story occupied multiple dwelling
- 1305 Engine 221 On Scene reports 10-75 (working fire)
- 1305 L108 10-84 (on scene)
- 1306 Mayday - seriously injured firefighters from ladder collapse

### **ANALYSIS**

An intensive investigation was conducted to determine if the aerial ladder collapsed because it was simply overloaded or if a defect in the design or construction, undetected damage, or some other factors may have contributed to its failure.

*Load Conditions* - To establish the elevation and extension of the ladder at time of failure, a similar vehicle was parked in the same location and the ladder was raised to the same window. To reach the window, the ladder was placed at an elevation angle of 31 degrees and approximately 91 feet, which is three feet short of its maximum extension (see Figure 3). It was rotated approximately 45 degrees to the right of the centerline of the vehicle.

The live load at the end of the ladder prior to the collapse was estimated at approximately 490 lbs., allowing 200 lbs. for each adult and 90 lbs. combined weight for the two children. The live load would have increased to approximately 690 lbs. when the father's weight was added. These estimates may be conservative, based on the size of the individuals and the weight of the protective clothing and breathing apparatus worn by the firefighter.

It is believed that the father dropped approximately three feet onto the ladder, which had already slipped off the window ledge. This would add a factor for the dynamic load. Witnesses reported that the tip of the left beam of the ladder was scraping against the brick wall below the sill and the entire ladder was oscillating before the father landed on the tip, which



Figure 3. Ladder Position and Angle: New York Ladder Collapse

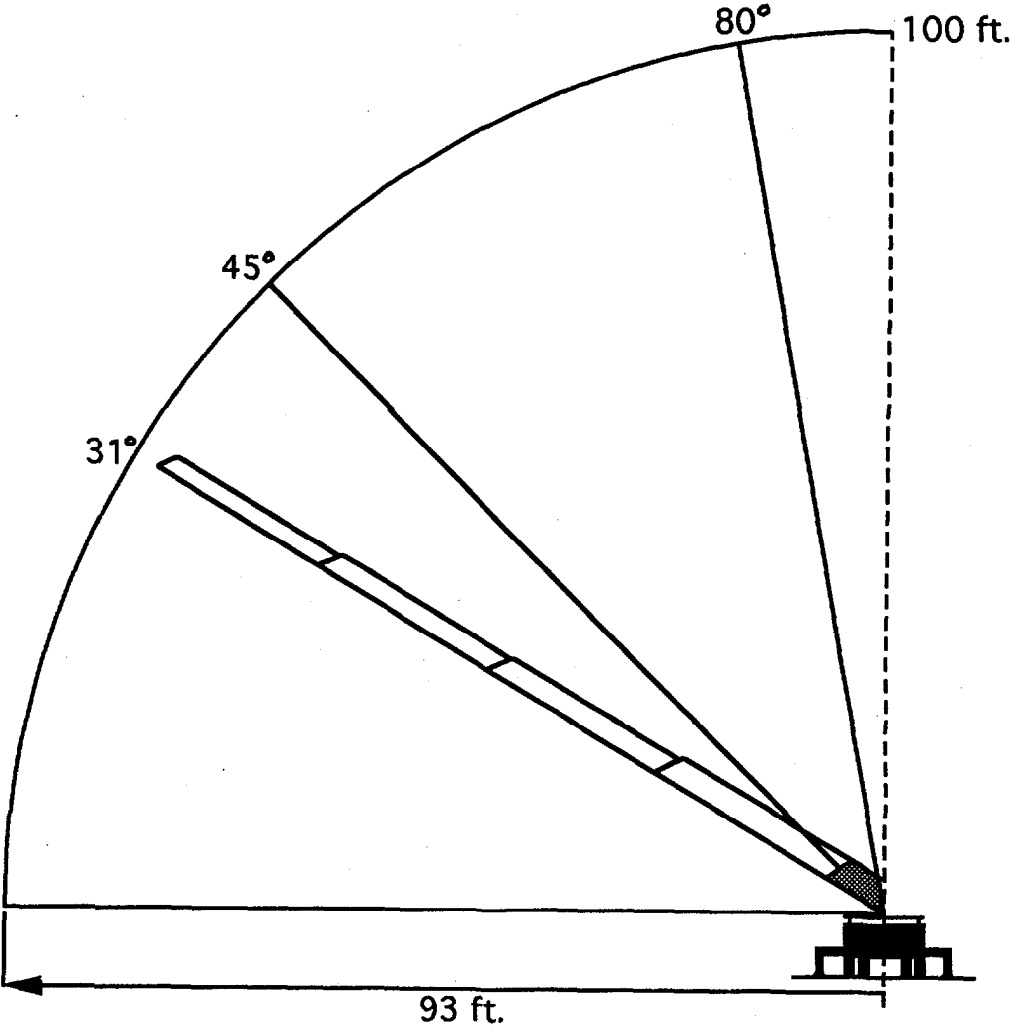

indicates that it was close to the point of failure and may have already begun to fail. It failed catastrophically when the added weight of the father was applied.

**Structural Analysis** — A consulting engineer was engaged by the City of New York to determine why the ladder failed. The damaged ladder was carefully inspected by the engineer for indications that the failure could have been caused by a manufacturing defect or by damage that had occurred prior to the collapse. The inspection did not identify any defects or pre-existing damage in the area where the failure occurred. No cracks in welds or structural members that appeared to be related to the cause were noted.

The primary structural failure occurred when the main beam on the lower right side of the bed section buckled inward, slightly above the point where it is supported by the ladder raising mechanism. This part of the ladder would be subjected to the maximum bending stress when the ladder is in a cantilever (unsupported) position. The buckling of the lower beam also crushed two of the rungs and caused a secondary buckling of the left main beam in the same area. The buckling indicates that the failure resulted from compression forces in the beam, which are caused by the bending stress in the ladder.

**Calculations** — The consulting engineer conducted a structural analysis of the ladder design to predict the failure mode and stress for each major component. The actual stress in each component was then calculated under the operating and loading conditions that existed at the time of failure. The comparison of these figures provides a prediction of where a failure is likely to occur and the load at the point of failure.

The ladder was constructed of high strength steel with a yield strength of approximately 70,000 lbs. per square inch. The structural analysis indicated that the lower beam, where the primary failure occurred, should buckle when subjected to approximately 50,000 lbs. (pounds of force) of compression. The load calculations estimated that the actual force applied to this member would have been between 48,000 and 54,000 lbs., depending on the allowance for dynamic load when the father dropped onto the ladder. These calculations confirmed that the lower right beam should have been at or very close to the point of failure in the area where the actual failure occurred and that the failure would be caused by compression of the beam. The compression force in the right beam would have been intensified by the tip of the left beam being in contact with the

wall; the twisting action would cause more of the load to be transferred to the right side of the ladder.

Based on this analysis it can be concluded that the ladder failed because the load exceeded the capacity of the ladder and not because of a defect in the ladder. The structural analysis also shows that the top chord of the ladder (the handrail) was at or very close to the point of tensile failure when the bottom chord failed in compression. (A copy of this report is provided in the appendix.)

***Apparatus Specifications*** — The truck involved in this incident was a Seagrave 100 foot rearmount aerial ladder with tandem rear axles and H-outriggers, similar to approximately 65 other Seagrave ladders built between 1980 and 1992 that are currently in service with the New York City Fire Department. It was one of 11 units that were delivered and placed in service in the department in 1992.

The purchasing process for the 11 vehicles was initiated prior to the effective date of the 1991 edition of NFPA 1904. The vehicles were built to New York City's specifications, which were dated April 13, 1989. Although the purchase specifications do not make reference to the NFPA standard, as far as can be determined, these vehicles complied with the 1985 edition of NFPA 1901, *Standard for Automotive Fire Apparatus*, which does not specify a minimum tip load. All aerial ladders purchased by New York City after the effective date of the revised standard meet the requirements of NFPA 1904, which was adopted in 1991 and requires a 250 lb. minimum tip load.

***Load Test Requirements*** — There are several different test procedures outlined in the purchase specifications and in the NFPA standards. The New York City purchase specifications called for the ladder to be subjected to four load tests:

1. A 200 lb. weight is secured to the tip of the bed ladder, then the ladder is fully elevated and rotated 360 degrees clockwise and counterclockwise.
2. The ladder is rotated 30 degrees from the centerline and extended to 85 percent of its length in a horizontal position. The 200 lb. weight is then attached to the tip and the ladder is fully retracted.

3. The 200 lb. weight is attached to the tip of the ladder, then the ladder is fully elevated, fully extended, and rotated 90 degrees within one minute.

4. The ladder is extended to 90 percent of its length at an elevation angle of 60 degrees and rotated to 15 degrees from the centerline over the rear of the truck. The ladder must support a 500 lb. test load suspended from the top rung of the fly section without deflecting more than 20 inches.

Two additional tests were specified using a ladder pipe to test the ability of the ladder to withstand horizontal nozzle reactions, first sweeping from left to right, and then a sudden shutdown of the ladder pipe.

The six tests listed in the New York City specifications are more demanding than the tests that were specified in the NFPA standard that was in effect in 1989, but considerably less demanding than the requirements that were adopted by the NFPA in 1991. The edition of NFPA 1901 that was in effect in 1989 only required the ladder raising mechanism to be able to lift a weight of 200 lbs., attached to the free end of the main section, from an unsupported horizontal position. This is similar to the first part of Test 1 in the New York City specification. It was not determined if all six tests were actually performed on the vehicle in question.

The aerial ladder failure was caused by bending forces that were applied to the ladder. The maximum bending force is applied when a load is placed at the tip of a horizontal, fully extended ladder. New York City's Test 2 places a load of 200 lb. on the horizontal ladder when it is extended to 85 percent of its full length, while the new NFPA standard requires an aerial ladder to support and operate with a 250 lb. tip load in the horizontal, fully extended position. The bending forces that are applied to the ladder in test 4 are approximately equivalent to 100 lb. load at the tip with the ladder horizontal and fully extended, if the weight of the ladder is taken into account.

The New York City test procedures require these loads to be supported without damaging the ladder, while the new NFPA standard requires the 250 lb. load to be supported with a minimum 2:1 safety factor in all structural members while the ladder is operated. This means that the newer ladders must have a much greater capacity to resist bending forces than the older ladders.

***Service Test Requirements*** — Service tests are intended to regularly evaluate the ability of an aerial ladder to operate and safely support the weights it was designed to support. Prior to 1988, the service testing procedures were specified in NFPA 1904, *Standard for Testing Fire Department Aerial Ladders and Elevating Platforms*. At that time the design requirements for aerial ladders were included in the 1985 edition of NFPA 1901, *Standard for Automotive Fire Apparatus*.

The service test requirements were extensively revised in 1988 and the testing document was reissued as NFPA 1914, *Standard for Testing Fire Department Aerial Devices*. This standard requires two load tests, both involving weights applied to the top rung of the ladder in a cantilever configuration. The first test is conducted with the ladder in a horizontal position at full extension or at the maximum extension recommended by the manufacturer when the ladder is in a horizontal position. The second test is conducted with the ladder fully extended at the maximum angle of elevation.

Standard 1914 does not specify the loads that must be used for the two tests, since the same procedure is used to test ladders that have different design specifications. The standard states that the test weights should be obtained from the load chart or the operator's manual supplied by the manufacturer. (The manuals that were provided with the New York City vehicle do not include this information.)

When the design requirements for new ladders were revised and issued as a separate standard in 1991, the number that had previously been used for the testing requirements document, NFPA 1904, was reassigned to the *Standard for Aerial Ladder and Elevating Platform Fire Apparatus*. The new NFPA 1904 incorporates the requirement for a minimum tip load of 250 pounds in any position.

***Operations Manuals*** — In addition to the test loads, the Operations Manual should provide all of the technical information that is needed by a trained user to safely operate a piece of equipment. It is very difficult to determine the specific operational capabilities or limitations of the ladder or the appropriate service test loads from the manuals that were provided with this vehicle.

The Seagrave Operation and Maintenance Manual provides information on allowable loads and operations in two different sections. The information on "Operational Loading Data" is found on pages 3 and 4,

while the instructions on reading the inclinometer are found on page 76. There is information relating to allowable loads on the ladder in both sections.

The section of the manual that refers to operational loading data emphasizes that “all consideration must be given to the tip-over stability of the truck, in addition to the safe loading of the ladder itself.” It goes on to state “The extension/hoisting data as printed on the inclinometer is to be followed exactly for the safest operation. The readings of the inclinometer should be followed and not more than one person and a ladder pipe should be on the outer end of the ladder with the inclinometer showing the maximum angle and extension that is safe from the standpoint of truck stability.” There is a note which adds that the extension figures may be exceeded by approximately 10 percent “with no load on the ladder, as when placing in position against a coping or window ledge.”

The inclinometer, which is mounted on the ladder, indicates the maximum allowable extension of the ladder at different angles of elevation. When raised to the position of Ladder 108 prior to its collapse, the inclinometer reading would allow 45 feet of extension for ladder pipe operations and 56 feet for use as a ladder only. The instructions state that these figures are based on an adequate margin of safety assuming that a person and/or ladder pipe is at the top of the ladder, which suggests that the ladder would be in an unsupported condition.

The “Climbing Angle vs. Load” section states “With the ladder unsupported (cantilever position) there is very little need for many people on the ladder. The inclinometer extension readings are safe for one person on the ladder and one person half way up.” However, the assumed weights of the persons on the ladder are not provided. In the case of Ladder 108, this appears to refer to the inclinometer reading marked “OFFSIDE OF TRUCK,” which indicates 56 feet at 31 degrees elevation. The inclinometer instructions do not clearly state if the extension limitations apply when the end of the ladder is supported; however, the 10 percent factor from the earlier section appears to apply to this situation. This would have allowed Ladder 108 to be extended approximately 62 feet at a 31 degree elevation angle.

The information provided by the manual clearly indicates that Ladder 108 was extended beyond the recommended operating range whether the tip was supported or unsupported. It cannot be determined

from the information provided in the manual if any weight could have been supported by the ladder in the configuration that it was used.

The “Climbing Angle vs. Load” section also provides maximum load recommendations at different angles, when the outer end of the ladder is supported. This section of the manual does not clearly state if there is a limit on extension when the tip of the ladder is supported. The loads are stated as the number of people that can safely be on the ladder at different angles of elevation. It states that the 100 foot ladder can safely support:

- 12 persons at elevations above 70 degrees
- 6 persons at 45 degrees
- 5 persons at 30 degrees
- 4 persons in the horizontal position.

These figures assume that the people are evenly distributed on the ladder and provide some allowance for load concentration and the weight of a live hose line or other equipment.

The manual does not provide the information that is needed to determine the loads that should be used to perform the horizontal and vertical service tests that are required in NFPA 1914. The only specific conclusion that can be drawn from the manual is that the horizontal load test should not be conducted with the ladder extended more than 45 feet.

The situation with one beam supported and one beam unsupported would make this question even more difficult to answer; however, this is widely recognized as an undesirable condition. Most aerial ladders, particularly the “old design” ladders, are known to be vulnerable to twisting actions, although this situation is not clearly addressed in the manual.

The manual includes several additional notes and cautions relating to different operating conditions. However, there is no reference to a condition when one beam is supported and one beam is unsupported. There is a caution that states “if the truck is on a grade that causes the truck to tip an appreciable amount, the loads and/or distance extended should be considerably reduced because of the stresses imposed sideways on the ladder.”

There are several statements in the manual which may cause confusion about the degree of risk that is involved if the ladder is operated outside the recommended range. One statement says “The inclinometer

readings are conservative and provide for perfectly safe operation under most conditions. They may be exceeded only with care and good judgment.” The inclinometer instructions add “The amounts of extension shown, at the respective degrees of inclination...should be exceeded only with caution and due consideration of unusual factors involved such as grades, crown streets, etc.” These statements suggest that the recommended loads and extension limitations can be exceeded, but they do not provide specific guidance on the conditions or limitations for exceeding the indicated operating limits. There is a caution that states “To load the ladder beyond the safe limits indicated could damage the ladder sections permanently.” However, there is no warning that the ladder could collapse.

The section titled “Operating Under Unusual Conditions,” which describes the use of the ladder for water rescue operations, includes a statement “bear in mind that the ladder is much stronger in a direction at right angles to the rungs than it is in a sideways direction.” This is the only reference to the relative weakness of the ladder to resist lateral (side) forces or twisting forces (see Figure 4). This section also states “Do not extend the ladder higher than necessary. The same principles apply to any unusual conditions or ladder loading.” There is no warning against placing the ladder so that one beam is supported and the other is unsupported.

*Conclusions* — Through a complicated series of events, Ladder 108 was placed in a position that was beyond the safe operating range of the aerial ladder and then very heavily loaded. It appears that the operator was skilled and very familiar with the apparatus and aware that the angle and reach were beyond the recommended limits; however, he had to make an immediate judgment call in a rescue situation and believed that the ladder would support the load. The rescue might have been successfully accomplished if there had been only one person at the window or if there had been time to bring the occupants down one at a time.

The angle and reach that were required in the situation encountered by Ladder 108 would have been within the allowable operating range of a newer ladder. Under the same circumstances the 250 lb. tip load rating would have been exceeded; however, it is unlikely that the ladder would have collapsed under the same operating conditions, particularly with the tip supported by the window sill. The safety factors that are incorporated in the design of the new ladders would have allowed this rescue to be safely accomplished with a newer ladder.



**Figure 4. Lateral Forces and Twisting Forces in Aerial Ladders**

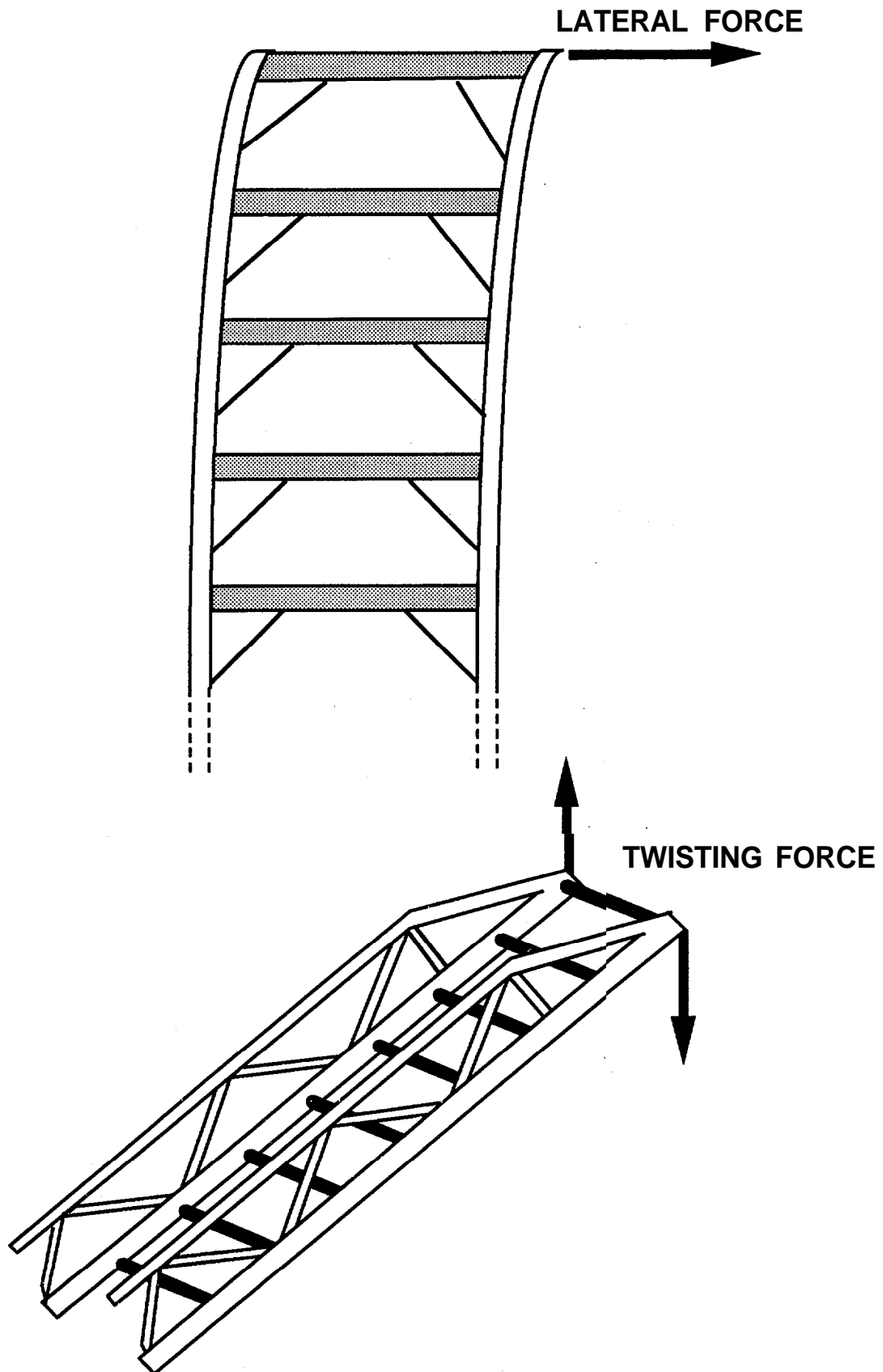

## **OTHER AERIAL LADDER ACCIDENTS**

Several additional accidents that involved aerial ladder failures have been reported. This section provides a brief description of four cases of aerial ladder collapse that occurred over a period of less than two years.

Each of these cases involved ladder failure, as opposed to overturning of the vehicle, which has been reported in several other cases. All four of the ladders involved in these incidents were "old design" designs, and their structural limitations appear to have been exceeded in each case.

### **Yonkers, NY - October 27, 1994**

A 1987 Seagrave 100 foot steel rear-mount aerial ladder, similar to the one that was involved in the New York City incident, collapsed during a structure fire. The ladder was being used in a ladder-pipe operation and collapsed onto the roof of an adjacent house. A firefighter who was operating the ladder pipe was injured when a twisting failure occurred in the first fly section, near where it joins with the bed section. The ladder rotated to the right and fell onto the roof of the house.

At the time of collapse, the truck was parked facing uphill on a slight incline. The ladder was nearly fully extended approximately 40 degrees and nearly perpendicular to the centerline of the truck. (The exact angle of elevation at the time of collapse is not known because the ladder operator tried to lower the ladder after noticing it was collapsing. The angle of elevation after collapse was approximately 40 degrees, but the angle was probably not much more than this at the time of collapse.) The metallurgist who inspected the ladder could find no visible defects or fatigue related problems that would have caused a failure. The operating conditions were beyond the limits indicated on the inclinometer for ladder-pipe operations.

### **East Chicago, IN - July 17, 1994**

A 100 foot steel Maxim ladder, originally constructed in 1959 and remounted on a 1980 Mack chassis, collapsed during a ladder-pipe operation at a large tire fire, injuring one firefighter. The ladder was extended approximately 50 to 70 feet at a 35 degree elevation angle and rotated approximately 15 degrees to the side of the truck. The ladder had not been inspected for at least two years. The ladder pipe was shut down

just before the collapse occurred, and a firefighter was in the process of ascending the ladder to survey the scene and reposition the nozzle. The firefighter was approximately 50 feet up the ladder when it buckled in the first fly section just above the bed. The firefighter was seriously injured and the aerial ladder was destroyed. The falling ladder became entangled in power lines which absorbed some of the impact. The power lines had been de-energized at the request of the Incident Commander.

### **Mundelein, IL - October 19, 1994**

An 85 foot steel Seagrave midship aerial ladder, originally constructed in 1962 and refurbished by the manufacturer in 1988, collapsed onto the roof of the fire station during a high angle rescue team training exercise. One week prior to the accident, an independent testing company inspected and certified the ladder to NFPA 1914 (version 1991) standards. The thorough inspection included ultrasonic and magnetic particle tests. The ladder had been extended approximately 80 feet at an elevation angle of 60 degrees and had been rotated approximately 20 feet to the right of the front of the truck. Firefighters were preparing to lift a stokes basket when the collapse occurred. The ladder twisted to the right and a bending failure occurred in the second section of the ladder. One firefighter was injured, suffering a badly sprained ankle when he fell approximately 12 feet.

The stokes basket was suspended from a rope that was passed over a pulley system. The pulley was attached to the top rung of the ladder and was offset approximately 18 inches from the centerline of the ladder. The rope ran down from the pulley at the tip of the ladder to another pulley that had been attached to a tow hook on the front of the truck. This pulley system was rigged to raise and lower the stokes basket.

After the collapse, an independent investigator was engaged to analyze the failure. The investigator also determined that the tip load had not been exceeded, but that the ladder failed due to a twisting force. The twisting force was induced by the rope running at an angle from the front tow hook to the tip of the ladder, and the offset of the pulley from the center of the top rung.

Twisting actions have been identified as a causal factor in several previous aerial ladder failures.

**Atlantic City, NJ - November 18, 1993**

A 1970 Pirsch 100 foot aluminum ladder collapsed during a ladder pipe operation, seriously injuring one firefighter. The ladder was extended 97 feet at an elevation angle of approximately 37 degrees, which was beyond the recommended extension limits for ladder pipe operations. The tractor-trailer vehicle had been parked in a jack-knife position. As a firefighter ascended the ladder, a twisting failure occurred in the bed section, approximately eight feet from the base of the ladder.

State investigators determined that there was no physical problem with the ladder which would have caused the collapse. The cause was attributed to operating the ladder in an unsafe manner.



Photos Courtesy Mundelein F.D.

Firefighters in Mundelein, Illinois were practicing a stokes basket evolution when their aerial ladder failed just above the bed section. The firefighters had run a rope through pulleys attached to the tip and the front tow hook (seen below), and were attempting to raise the basket when the collapse occurred.





Courtesy Mundelein F.D.

This photo shows a close-up view of the point of failure just above the bed section in the Mundelein incident. Ladder failures often occur at this point in the ladder.



Courtesy Mundelein F.D.

Cross section of the main beam of the Mundelein ladder after it was cut to remove the damaged sections. The beam is assembled from several section of flat steel strips which are bent to form the flanges and then welded together to create the I-beam shape. The interior of the beam is hollow.



Courtesy Yonkers F.D.

A Yonkers, New York aerial ladder failed during ladder pipe operations.



Courtesy Yonkers F.D.

The ladder failed in the first fly section just above the bed section.

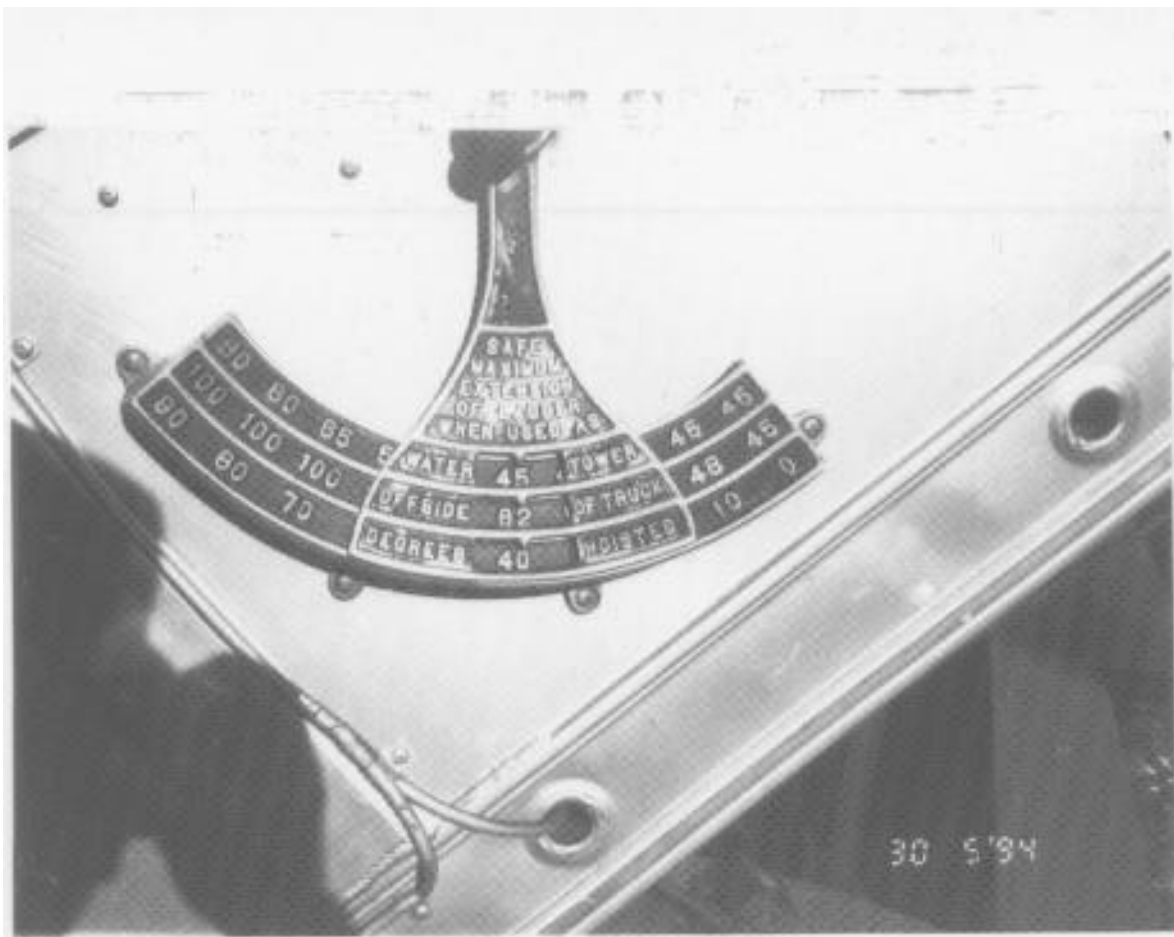

Courtesy Yonkers F.D.

Although the exact angle of elevation at the time of the Yonkers collapse is unknown, the ladder was fully extended at an angle estimated at less than 50 degrees. The inclinometer shows that the maximum safe extension at 40 degrees elevation for a water tower operation is 45 feet.



## ANALYSIS

All five of the incidents described in this report involved “old design” aerial ladders and all of the failures occurred during operations when the ladder was in a cantilever configuration (unsupported at the tip). Each of the ladders collapsed, resulting in nine injuries to firefighters or civilians and one fatality. Four of the five situations involved operation of the ladder beyond the recommended extension at low elevation angles. Only one of the accidents occurred during a rescue incident.

This report does not address incidents when the vehicle overturns, as opposed to collapse of the ladder itself. One of the most common causes of accidents with aerial ladders and platforms is the failure to adequately support the vehicle using jacks and outriggers. Several instances of vehicles overturning have been reported, involving failure to extend and lower the outriggers, placement of the outriggers on unstable ground, failure to use ground plates to spread the load over a larger surface area, and problems with the jacks and outriggers themselves.

Most aerial ladder failures involve a combination of overloading and over extension at low elevation angles, which can result in overturning or structural failure of the ladder. Aerial ladders are susceptible to catastrophic failure when the ultimate capacity of one or more critical members or connections in the ladder assembly is exceeded. These situations may involve bending stresses, twisting stresses, or a combination of bending and twisting.

The “old design” ladders are much more susceptible to structural failure than the newer ladders because they were not designed to support the load capabilities that are required by the new standards. The older ladders have proven to be very safe and reliable when operated within their design limits; however, they were not designed for low angle operations. Advances in aerial ladder technology have made the newer ladders widely available.

***Operator Training*** — It is extremely important for aerial apparatus operators to be well trained and thoroughly familiar with their equipment, particularly for the older models which can be placed in configurations where they cannot be safely used. One of the significant features of the new standards is that they provide a minimum basic load capacity that applies to any operating configuration.

The operator training program must address the operational limitations of ladders. While conducting the research for this report, several aerial ladder operators were encountered who had no knowledge of the actual load capacities of their ladders in low angle situations. These individuals were generally well trained and skilled in operating the apparatus, but had not been trained in the limitations of their equipment.

***Operating Manuals*** — In many cases the operating manuals for aerial ladders and other apparatus are not available to the operators. While they may have been delivered to the fire station along with the vehicle, the manuals are often lost or misplaced over the years. Some fire departments have been known to keep all of their manuals at a central maintenance division, but fail to make them available to the operators. The manuals should always be with the vehicle; they should be carried inside the vehicle or kept at the station where the vehicle is located.

The manual is not intended to guide the user when the vehicle is being operated, but it is an essential source of reference and training information. It is usually not feasible to refer to the manual during an incident - the operator should be sufficiently familiar with the apparatus and its operating characteristics and limitations to operate it safely and competently without having to refer to the manual. The manual should always be available to the operator for training, familiarization and trouble shooting. This can be particularly important when a spare vehicle is sent to a station to replace the regular unit. If the manual does not provide sufficient information to guide the operator, the fire department should contact the manufacturer to obtain the missing information and ensure that it is obtained and kept with the vehicle.

***Inspection and Testing*** — The need for regular inspection and testing of aerial apparatus should be widely recognized within the fire service. Aerial ladders may be damaged through use or misuse, may deteriorate from corrosion, metal fatigue or other causes, or may have undetected design or construction defects. Some of these problems may be undetectable without sophisticated testing, which requires the proper equipment and skilled technicians. The recommended test procedures that are specified in NFPA 1914 should be followed by all fire departments on a regular schedule and whenever a structural problem is suspected.

All aerial apparatus should be regularly inspected and tested according to the applicable NFPA standards and the manufacturer's documentation. There are several recognized private organizations that can

inspect, test and certify aerial ladders for a reasonable cost. Ladders that have not been properly tested and certified should not be in service.

Failure Analysis - An aerial ladder is a complicated assembly of trusses which telescope together. Each larger section of the ladder is significantly stronger than the individual sections that telescope into it, and the assembly is particularly strong where the sections overlap. In a cantilever configuration, bending stress creates tension forces in the top chord (the handrails) and compression forces in the bottom chord (lower beams), which increase in magnitude from top to bottom. When the tip of the ladder is supported the top chord is in compression and the bottom chord is in tension. A cantilever configuration creates greater bending stresses in a ladder than a supported configuration.

Simple bending failures often occur at the point where the first section extends out of the bed ladder, as shown in several of the incidents discussed in this report. At this location the ladder is subjected to the greatest bending forces in any of the telescoping sections, just prior to the point where the load is transferred to the bed ladder. The bending forces continue to increase in magnitude down to the bottom of the ladder; however, the bed ladder has a much greater capacity to resist bending stresses than the telescoping sections. Failures that occur at this location often involve elongation of the handrails when their tensile capacity is exceeded, or buckling of the lower beams due to compression forces, allowing the upper portion of the ladder to droop.

The New York City collapse occurred when the capacity of the lower beam to support the compression forces was exceeded. The ladder was subjected to twisting forces caused by the contact between the building and the tip of the left beam (see Figures 2 and 5). In this situation the twisting increased the compressive load on the bed ladder at the location where the maximum bending stress is applied to the ladder, just above the area where the load is transferred to the vehicle. The inward buckling of the beam caused the right side of the ladder to fail first, which caused the ladder to twist to the right as it fell.

Twisting actions can be extremely damaging to aerial ladders. Any action that twists a ladder creates complex forces that may overload individual members or cause the ladder sections to become disengaged, leading to catastrophic failure. A twisting failure can occur at any point in a ladder where the stress in a particular member or at a connection exceeds its capacity. However, the failure is most likely to occur at a point

Figure 5. Forces in Ladder in Cantilever and Supported Operating Modes

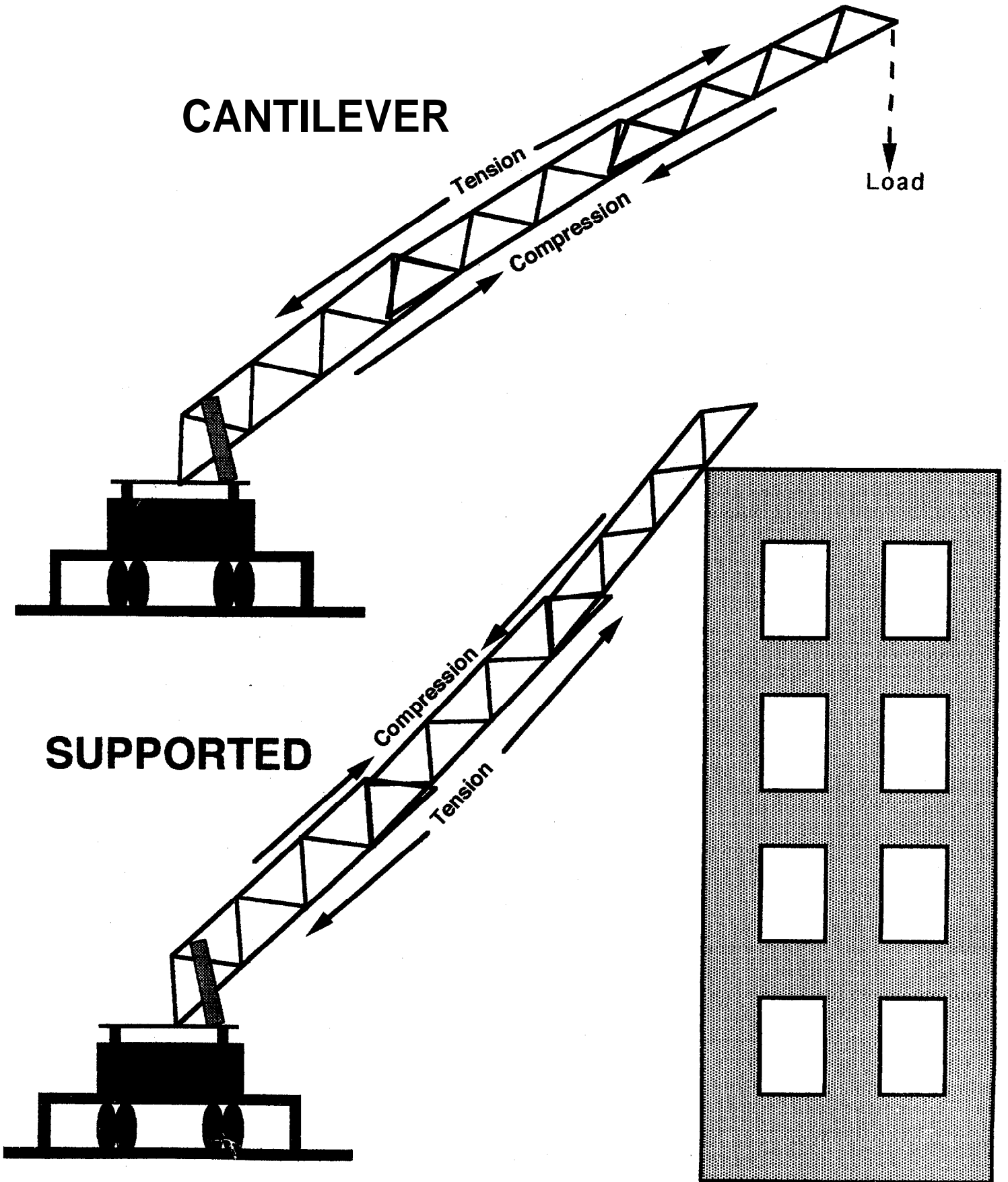

where the member or connection is already highly stressed to support the load, particularly if the member is defective or damaged.

Most aerial ladders are much less resistant to lateral forces than vertical forces. Lateral forces are most likely to cause a sideways failure near the base of the ladder. Most of the newer ladder designs have significantly improved resistance to lateral forces with the addition of K-bracing between the rungs and the side trusses.

***Operating Conditions*** — Four of the cases described in this report involved an excessive load being applied to the end of the ladder when it was overextended at a low angle. In the New York City incident the excessive load was the weight of the people on the ladder, while two of the cases involved the combined weights of a ladder pipe and a firefighter on the end of the ladder.

Several aerial ladder failures have occurred when a ladder pipe was shut down after being operated at a low angle. The nozzle reaction from the ladder pipe helps to counteract the force of gravity and assists in supporting the weight of the ladder, as long as water is flowing. When the ladder pipe is shut down, the extra support is suddenly lost and the ladder may be too weak to support the weight of the ladder pipe, plus the hose and water, as well as the firefighter who may have been operating the ladder pipe. The effect is magnified if the ladder pipe has been operated by remote control and a firefighter walks out to the tip of the ladder to evaluate conditions at the same time as the ladder is shut down.

Water rescue operations have resulted in several ladder failures, when aerial ladders were extended as far as they would reach in an attempt to reach people in the water. In these situations, it is easy to overload a ladder or to create lateral or twisting forces that can cause a ladder to collapse.

Several aerial ladder failures have also been reported when suspended loads, such as high angle rescue equipment have been attached to the tip of a ladder. These loads may cause damage that ranges from a bent rung to catastrophic failure of the ladder. While the ladder may have the capacity to support the weight, depending on the angle and extension, the suspended load may twist the ladder sufficiently to cause a catastrophic failure, particularly if the attachment of the load to the ladder can create lateral or twisting forces in the ladder. Before a department utilizes an

aerial ladder for crane-like hauling operations, it should contact the manufacturer to verify that the ladder can support this type of operation. Written documentation should be obtained to ensure that the proposed operation has been properly evaluated and the limitations are well defined.

*Specifications* — Every fire department should be familiar with the specific capabilities and limitations of the apparatus in its fleet. When purchasing new or used apparatus, the operating characteristics should be researched to ensure that they will perform the functions that can be anticipated in the community. Experience has shown that a capability for low angle, long reach operations is required in most communities.

*New Technologies* — Several new technology safety features are available for specification when aerial devices are purchased, however the feasibility of retrofitting on existing vehicles is very limited. Load monitoring systems, which sound an alarm to warn the operator when the ladder is overloaded, can be installed to avoid overloading. Overextension alarms can alert the operator when the ladder is extended beyond a safe distance at various angles. Interlock systems can stop the movement of an aerial device when it is in an unsafe configuration and prevent operations when the vehicle has not been properly stabilized. These systems do not substitute for good operator training, but they may stop an operator from making a simple error that leads to a major accident. All of these devices must be custom designed for each particular application.

*Operator Training* — All operators must know the operating limits and characteristics of their apparatus. Operator training should include very specific knowledge of each type of vehicle, and vehicle-specific training should be required before an operator is authorized to operate an aerial ladder.

## **LESSONS LEARNED**

These ladder failure incidents demonstrate that aerial ladders have specific design and usage limitations which, if exceeded, can result in serious injury. Lessons learned from the collapses discussed in this report are summarized below.

1. Aerial ladder operators must be well trained about load and operational limitations of aerial ladders before being authorized to operate them. Training should emphasize safe practices and make operators familiar with limitations and unsafe operating practices.

2. “Older design” apparatus which do not meet current standards have varying: load and extension limitations. Exceeding: these limitations can cause a ladder to collapse. Aerial ladders designed to meet the load requirements of the 1991 version of NFPA 1914, *Standard for Aerial Ladder and Elevating Platform Fire Apparatus*, are required to safely support a minimum load of 250 lb. in any position that the ladder will reach.
3. Fire departments that operate ladder trucks with different capabilities and limitations must ensure that all operators are trained in the operating: procedures and limitations of each type of unit they could be expected to operate. This can present a significant problem if companies that are normally assigned new apparatus with few operating limitations are temporarily assigned reserve apparatus with more limited capabilities. When assigning reserve apparatus, it is important to ensure that operators are aware of the differences in operating capabilities.
4. The allowable live load on a ladder decreases rapidly at low angles and greater horizontal extension. Many “old design” aerial ladders can be placed in configurations where the ladder was not designed to support any live load.
5. Operating: manuals provided upon deliver-v of an aerial ladder truck should be kept with the ladder and available for reference by the aerial operator at any time. The manuals should provide specific information about the aerial ladder’s capabilities and limitations.
6. Manufacturers of aerial apparatus should provide manuals and training materials that clearly present the operational requirements and limitations of each device.
7. Fire departments which are unsure about the limitations and safe operating practices of an aerial ladder should contact the ladder manufacturer to verify the ladder’s capabilities. The fire department should request a written response with specific information on the recommended use and limitations of the device.
8. All aerial ladders should be regularly inspected and tested to ensure that they are safe and in proper condition for continued operation. The strength of ladders may deteriorate for any of several reasons, including corrosion, fatigue, wear, stress, or mechanical failure.

9. Fire departments that have areal apparatus that does not meet current requirements should contact the manufacturer to determine the feasibility of limited use, such as installing equipment to limit extension or removing the fly section.

10. When aerial ladders fail, it is important to gather information about operating conditions and to obtain a professional engineering assessment of the cause.

## **ACKNOWLEDGEMENTS**

The U.S. Fire Administration acknowledges the assistance of the individuals listed at the beginning of this report for providing specific information about aerial collapse incidents in their jurisdictions. Their openness to provide and share information about ladder collapses helps other departments recognize potential hazards in operations and limitations in design so that aerial ladder operational safety can be improved.



**Appendix**

**Independent Report on  
New York City Ladder 108 Collapse**

**Arthur D. Little**

Failure Analysis of a  
100 ft Aerial Ladder

Report to Fire Dept. New York

February 7, 1995

Arthur D. Little, Inc.  
Acorn Park  
Cambridge, Massachusetts  
02140-2390

Reference 48260

## **Introduction**

On November 21, 1994, an aerial ladder collapsed while being used to rescue several people. One fatality and several serious injuries resulted. Because of this, the Fire Department of New York sought to establish the cause of failure so that mitigating measures for other ladders could be established, if appropriate.

This report describes the approach taken in and the results of a study conducted by Arthur D. Little to determine the cause of the ladder failure. The results are tentative, because they are based on a single examination of the ladder, preliminary information about the conditions surrounding the failure and some analytical engineering calculations based on some assumed properties of the ladder. Very little information was available from the manufacturer of the ladder, Seagrave, during the course of the study.

Nevertheless, we have arrived at two primary conclusions:

- the mode of failure was buckling; we could find no evidence that defects or damage to the ladder contributed to the failure;
- the maximum load carrying capacity of the ladder, for the angle of use during the rescue operation, was exceeded when the father jumped onto the ladder.

The remainder of the report summarizes the details that support these and other conclusions.

## **Accident Conditions**

Our understanding of the conditions surrounding the accident are based primarily on descriptions provided by FDNY staff and photographs made at the scene subsequent to the accident.

The rescue operation involved extending a 100 ft aerial ladder, No. 75651, approximately 95 ft to the sixth floor window of a building. The vertical inclination of the ladder, as determined from the gauge on the truck and from a scrape mark on the brick of the building, was 30 degrees to the horizontal. We did not obtain the horizontal inclination with respect to the side of the building but it appears to have been about 30 degrees. Initially, the ladder was supported on one side of the tip of the fly section on the window sill of the sixth floor.

As reported to us verbally, a firefighter had climbed to the window on the ladder, was handed two children, ages four and five, and was beginning his descent when the mother climbed out of the window and onto the tip of the ladder. The ladder then

apparently came away from the window sill and was oscillating up and down when the father jumped onto its tip, which was now about three feet below the sill. It was at or around this time that the ladder collapsed to the ground. As described to us, it was uncertain whether the ladder actually began its collapse before or after the father jumped onto the tip.

That the father was loading the tip of the ladder as it failed is supported by his eventual location on the ground, which was immediately adjacent to the ladder tip and several feet to the side of the point immediately under the window. This is consistent with falling along the trajectory of the tip of the ladder.

The weather at the time of the accident was cool and there was no significant wind. Estimated weights of the people on the ladder. were: firefighter, mother and father - 200 lb each; children - 90 lb combined.

### **Ladder Description**

The 100 ft aerial ladder was manufactured by Seagrave Fire Apparatus, Inc., Clintonville, Wisconsin. It was purchased according to a specification that required, among other things, that it withstand a 500 lbf load suspended from the top rung of the fly section when the ladder is extended 90 ft at an angle of 60 degrees to the horizontal without deflecting more than 20 inches.

The ladder is made up of four sections, which are similar in construction. Each section consists of a pair of truss structures, one on each side, which provide primary ladder strength, and a hand rail (Figure 1.) These side truss sections are connected by rungs. Each section also includes equipment for extending the ladder and to ensure interlocking.

The ladder structural material is steel, referred to in the Seagrave manual as 'Hi-Form 60 steel with a tensile strength of 70,000 pounds per square inch' (psi). Hardness tests made on a piece removed from the hand rail indicate that the tensile strength of the steel is 75,000 psi.

The bottom chord of the truss sides appears to be custom made and has the shape of a hollow I-beam section, Figure 2. Approximate dimensions of this cross section as well as the overall dimensions of the four ladder sections were made during examination of the ladder. For example, the I-beam chord has a flange width of a little over 2 inches and a height of between 4 and 4.25 inches. The railing, which forms the top chord of the truss, is a square tube section, 1.5 inches on a side at the bed section.



OFFICIAL PHOTOGRAPH NEW YORK FIRE DEPARTMENT

Figure 1. View of a 100 ft Aerial Ladder, Similar to the Failed Ladder, at the Site during Reconstruction of the Accident Conditions. This Figure also Shows the Truss Structure of the Ladder Sides.

**Arthur D. Little**



OFFICIAL PHOTOGRAPH NEW YORK FIRE DEPARTMENT

Figure 2. Photograph of Sections of the Failed Ladder after Disassembly and Storage. Bottom Chord Cross Section is Shown in the Lower Right Corner.

**Arthur D. Little**

## **Examination of the Failed Ladder**

Photographs of the ladder subsequent to the accident, before it was removed from the truck, showed a significant buckle at the bed section, Figure 3. While significant deformation occurred on other parts of the ladder, it appears that the primary location of failure is at the bed section and other deformation resulted during impact of the fly section with the ground. Therefore attention was focussed on the bed section.

The buckling deformation that occurred in the bed section appears to have initiated as two 'hinges' in the bottom I-beam chord. The 'hinges' were located at the first two vertical structural members on the right side of the ladder (looking up from the bed section), Figure 4, and are separated by about 42 inches along the ladder. The buckling of this right-hand chord was accompanied by buckling and 'hinge' formation in the adjacent rungs and some lesser amount of buckling deformation in the left hand chord of the ladder, Figure 4.

Detailed examination of the structural members in and around this buckled zone failed to reveal any evidence of preexisting cracks, dents or other damage that might have contributed to the failure. All cracks observed have the characteristics of overload failure, consistent with having been caused by the large buckling deformations.

Examination of the hand railing, which forms, the top chord of the structural truss, showed no signs of cracking. It was unclear how much, if any, stretching of this member occurred prior to total collapse and impact with the ground.

## **Analysis**

*Note: The quantitative values presented in this section are based on approximate measures and some assumptions on dimensions and material properties of the ladder components. No detailed information, such as mechanical drawings or material specifications were available from the manufacturer during the course of this study.*

The purpose of the analysis was to determine the ladder tip failure load for the extension and inclination corresponding to the accident. Only the assumptions used and key results will be described here. As noted in an earlier paragraph, the ladder derives its strength and stiffness from its sides which are essentially structural trusses with the I-beam section as bottom chord and the hand rail as the top chord.

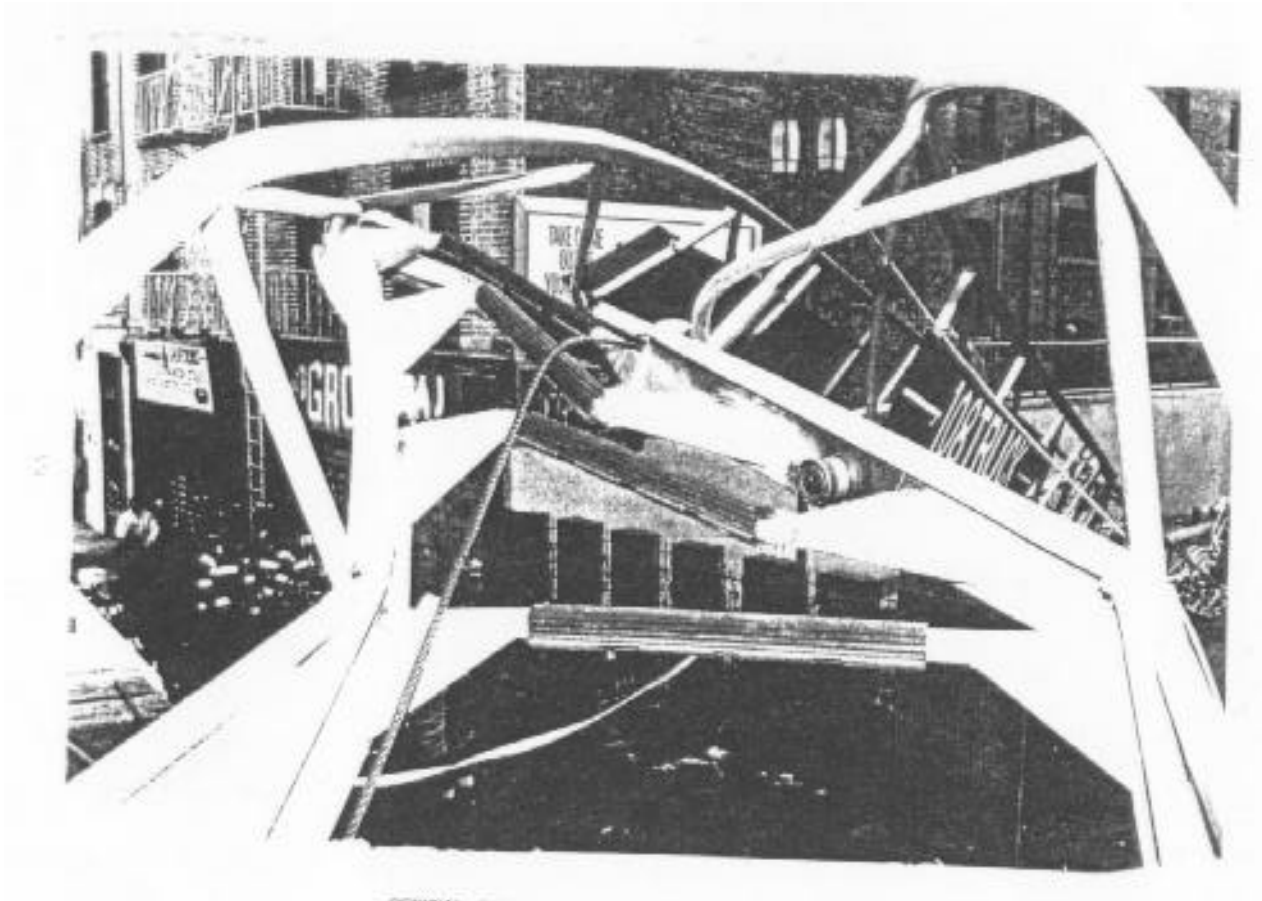

OFFICIAL PHOTOGRAPH NEW FOR FIRE DEPARTMENT

Figure 3. Photograph of the Buckled Bed Section in the Failed Ladder at the Site of the Accident.

**Arthur D. Little**



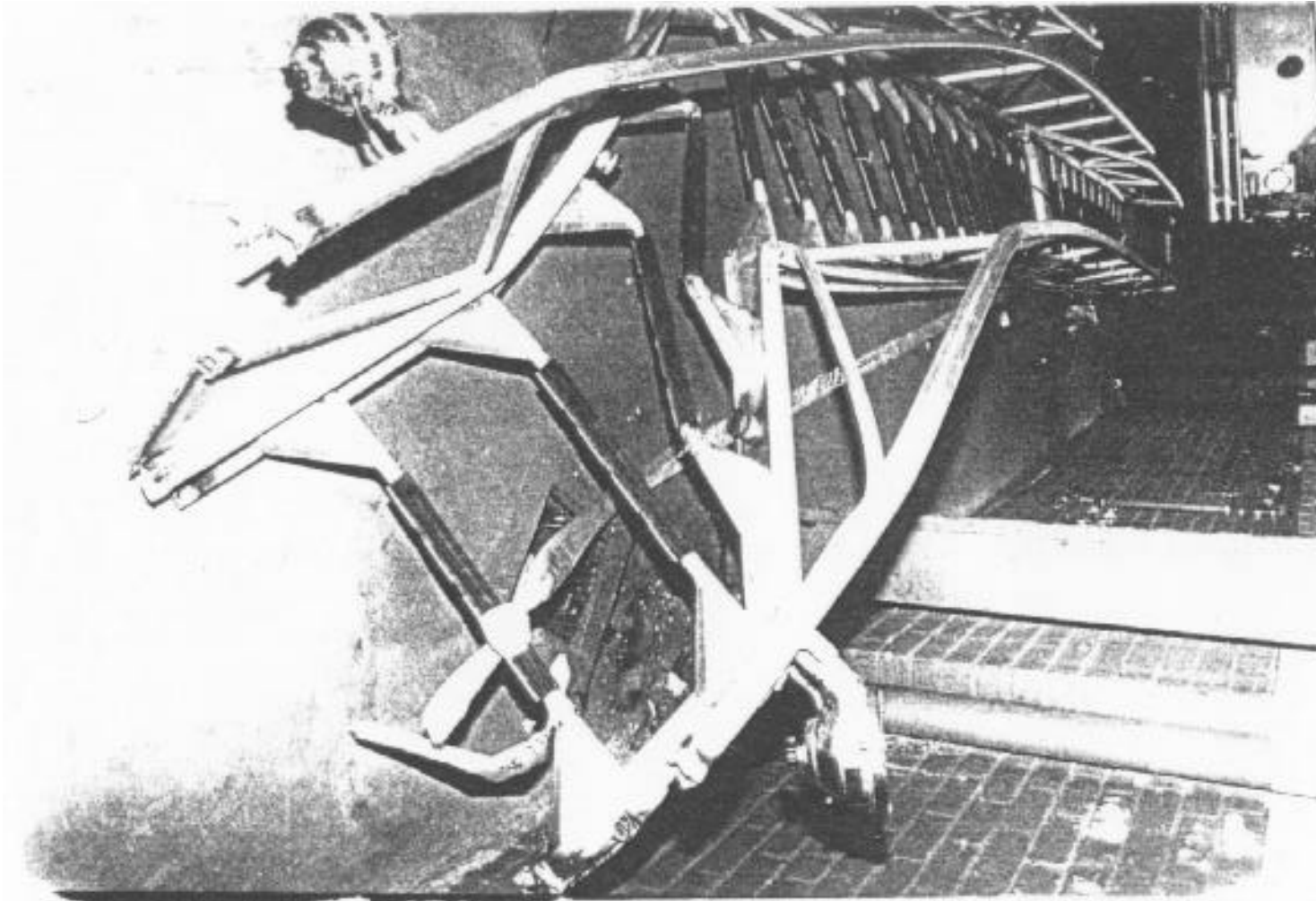

OFFICIAL PHOTOGRAPH NEW YORK FIRE DEPARTMENT

Figure 4. Photograph of the Bed Section of the Failed Ladder Showing the Buckled "Hinges" in the Right Bottom Chord.

In deriving the failure load we first established the relationship between the load at the tip of the ladder and the load in the bottom and top chords of the trusses. We then determine the failure loads for the top and bottom chords to determine at what ladder tip load they were exceeded.

When extended at any practical inclination, the trusses are loaded in bending with the bottom chord in compression and the top chord in tension. The load in the bottom and top chords is greater for sections closest to the bed and in fact the load is a maximum at the bed. The loads at this location are determined by the bending moment induced by two components: the live load, which is the weight of the people, in this case, near the tip, and the dead load, which is the weight of the ladder, effectively acting near the center of the fully extended ladder. The bed bending moment contribution of a given load is equal to the weight times the horizontal distance of the weight from the bed. (Note that shallower ladder inclinations cause greater moments for the same weight.)

In carrying out our calculations, we considered two cases of live load and a dead load of 2,500 lb, which corresponds to the approximate weight of the ladder above the location of the lower buckle hinge in the bed section. The two cases of live load are as follows:

**Case 1.** The firefighter, two children and the mother located at 95 ft from the bed section under consideration, after the ladder has detached from the window sill.

**Case 2.** The loading in 1. *and* the load from the father jumping onto the tip of the unsupported ladder from a height of 3 ft.

The static weight in these two cases is approximately 490 lb and 690 lb, respectively. However, the dynamic loads as a result of the ladder having come detached from the sill and from the father jumping onto the ladder tip are estimated to be substantially greater: 980 lb for Case 1. and 1,230 lb for Case 2. It is possible that the dynamic load for Case 2. is even larger, especially if the father jumped while the ladder was still oscillating and it was in the downward part of that oscillation.

As a note, in terms of bending moment, a load of 980 lb at the tip of a ladder extended 95 ft at an inclination of 30 degrees, is equivalent to a load of over 2,500 lb at the tip of a ladder extended 90 ft at an inclination of 60 degrees, including the effect of the ladder weight.

The higher, dynamic loads can be understood by considering that dropping a load onto a spring will cause the spring to deflect more than it would if one set the load onto the spring very slowly. Since load is proportional to spring deflection, the load

is higher in the dynamic case than the static case. In fact, the unsupported ladder acts very much like a spring.

Given the ladder tip loads and the weight of the ladder, the loads in the bottom and top chords at the bed section could be calculated. Truss analysis shows that the load magnitude in the top chord is about 95% of the load magnitude in the bottom chord. Our approximate calculations suggest that chord loads for the two cases are:

Case 1:           Bottom chord = 48,000 lbf  
                    Top chord = 46,000 lbf

Case 2:           Bottom chord = 54,000 lbf  
                    Top chord = 52,000 lbf.

Our estimate of the failure load of the bottom chord is 50,000 lbf. This failure load is based on a buckling mode. On the other hand, the failure load for the top chord is estimated to be 52,000 lbf and is based on a fracture mode. We estimate that yielding (stretching) of the top chord would occur at a load of about 42,000 lbf. However, without detailed knowledge of the materials used, we cannot say how much stretching would occur prior to fracture.

## **Conclusions**

The results of our examination of the failed ladder and our analytical calculations indicate that the ladder could not sustain the tip loading of the fire fighter, the two children and the two parents, especially with the dynamic load caused by the father jumping from the window, for the extension and inclination at the time of failure. The tip loading exceeds the estimated failure load by about 10% in this case. The results also indicate that the ladder was close to failure when loaded by the fire fighter, the two children and the mother when the ladder became detached from the window sill. The tip loading in this case is about 5% less than the estimated failure load. Our results are based on verbal reports of the conditions at the time of the accident and approximate data on the geometry and materials of the ladder. Finally, we note that the failure does not appear to have been caused by any defect in or damage to the ladder.